

# Pink is tough: A quick guide to timber treatment for enclosed framing



If you're using radiata pine or Douglas fir timber for enclosed framing in buildings, the Building Code states it must be treated to hazard class H1.2. This guidance may help you to understand how H1.2 works and why you need to treat timber used for framing.

Published on 1 April 2011

1st edition

ISBN: 978-0-478-34383-0 (Print) / 978-0-478-34384-7 (Online)

## A new timber treatment system for Acceptable Solution B2/AS1

- tough against fungal decay and insect attack
- simpler and easier to use
- protects framing from decay
- time and cost effective.

Timber treatment in Acceptable Solution B2/AS1 has changed to a new, simpler system:

If you are using the Acceptable Solution to demonstrate compliance with the Building Code, H1.2 is now required for nearly all radiata pine and Douglas fir enclosed timber framing.

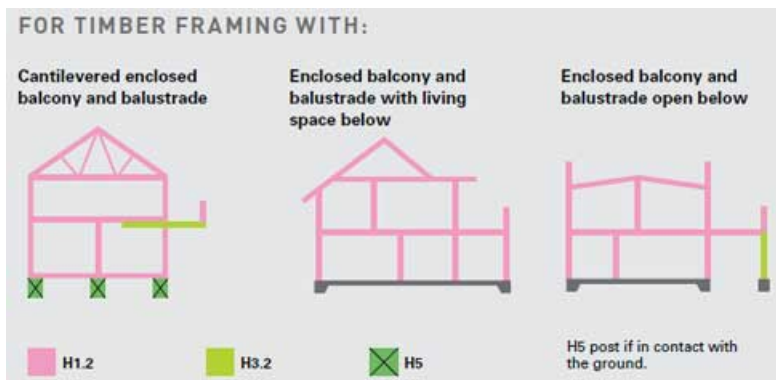

What's new with timber treatment?

The Acceptable Solution B2/AS1 has changed. The timber treatment hazard class H1.2 is now required for radiata pine and Douglas fir timber in buildings, where it is protected from the weather (such as, enclosed timber framing). Consult the tables in this booklet for the few exceptions to H1.2 treatment.

### Why H1.2?

Research shows that H1.2 gives framing timber good protection from decay. H1.2 boron treatment is colour-coded pink.

### How can I be sure my timber framing complies with the Building Code?

The changes in this booklet outline one way to comply with the New Zealand Building Code durability clause B2. However, the booklet is only a quick guide, so consult Acceptable Solution B2/AS1 for full details.

### Why continue to treat timber?

Timber must be adequately protected against damage from fungal and insect attack so that buildings are durable and comply with the Building Code. The new system improves the overall level of protection against decay.

### What about other species of wood for framing?

For other species of wood and engineered wood products (such as LVL and Glulam), the Acceptable Solution does not change. For information on other species which can be used under the Acceptable Solution, consult NZS 3602:2003 Tables 1 and 2.

## The Building Code and Acceptable Solution B2/AS1

---

This booklet is a quick guide to timber treatment changes in the Acceptable Solution B2/AS1. Designers should consult B2/AS1 itself for more information on timber treatment.

MBIE's Acceptable Solution B2/AS1 can be found in **B2 Durability** (<https://www.building.govt.nz/building-code-compliance/b-stability/b2-durability/>)

# Glossary

---

## Building Code and B2

The Building Code sets out performance standards that building work must meet. It has 35 technical clauses covering requirements such as managing external moisture, structure and ventilation. Clause B2 is the technical clause for durability and includes timber treatment. It sets out the durability requirements for all building elements.

## Acceptable Solution

An Acceptable Solution details one way to comply with the relevant part of the Building Code. If you follow this method, your building work will meet that part of the Building Code. B2/AS1 is an Acceptable Solution for clause B2 (Durability) of the Building Code.

There can be ways of complying with the Building Code other than through an Acceptable Solution - these are often called alternative solutions.

## H1.2

This is a hazard class for timber treatment. A hazard class defines the risk and the level of timber treatment, as specified in NZS 3640 and NZS 3602.

## Building Envelope

This describes the exterior surfaces (wall cladding, roofing, windows and doors) of a building.

For full details check B2/AS1

# Overview of Timber Treatment for Radiata pine and Douglas fir

For full details check [B2/AS1 \(https://www.building.govt.nz/building-code-compliance/b-stability/b2-durability/b2-acceptable-solutions-and-verification-methods/\)](https://www.building.govt.nz/building-code-compliance/b-stability/b2-durability/b2-acceptable-solutions-and-verification-methods/)

Where timber treatments are used		
Level	Species	Building Element
<b>Floor framing protected from weather but exposed to ground atmosphere</b>		
H1.2	Radiata pine Douglas fir	Jackstuds, subfloor braces, wall plates, floor joists to the subfloor, blocking, walings and battens, nogs and diagonal boards
H1.2	Radiata pine Douglas fir	Interior solid wood flooring for ground floors
<b>Enclosed roof framing and trusses</b>		
H1.2	Radiata pine Douglas fir	Sarking and framing not protected from solar-driven moisture through absorbent cladding materials
H1.2	Radiata pine Douglas fir	Enclosed flat roof framing and associated roof members
H1.2	Radiata pine Douglas fir	Enclosed skillion roof framing and associated roof members
H1.2	Radiata pine Douglas fir	Valley boards and boards supporting flashings for box gutters, roof penetrations and upstands to roof decks
H1.2	Radiata pine Douglas fir	All roof trusses, including gable end trusses, roof framing, ceiling and eaves framing, purlins and battens
<b>Enclosed wall framing protected from the weather</b>		
H1.2	Radiata pine Douglas fir	Framing and other members within or beneath a parapet
H1.2	Radiata pine Douglas fir	Framing and other members within enclosed decks or balconies (see H3.2 for cantilevered decks)
H3.2	Radiata pine	Framing and other members within enclosed cantilevered decks (including joist trimmers, nogs and blocking)
H1.2	Radiata pine Douglas fir	Framing and other members supporting enclosed decks or balconies (including for cantilevered decks)
H3.1	Radiata pine	Battens used behind cladding to form a cavity (H3.1 treatments can be either solvent-based or boron. H3.1 boron treatments supplied grey primer-painted)

H1.2	Radiata pine Douglas fir	All other exterior wall framing and other members including exterior and boundary joists
<b>Internal Wall Framing</b>		
H1.2	Radiata pine Douglas fir	Internal walls
<b>Mid-floor framing</b>		
H1.2	Radiata pine Douglas fir	All mid-floor framing, including boundary joists, ceiling framing and ceiling battens and double top plates
<b>Interior flooring</b>		
H1.2	Pinus species Douglas fir	Interior flooring
<b>Other framing</b>		
None	Radiata pine Douglas fir	Wall framing and roof framing (including trusses) protected from the weather, in unlined and unoccupied farm buildings and outbuildings, except buildings with high internal humidity, such as saunas, spas etc
H3.2	Radiata pine	Framing exposed to the weather and above ground
H4	Radiata pine	Framing, such as fence posts and landscape timbers, that is exposed to the weather and is in contact with the ground
H5	Radiata pine	Framing, such as house piles, poles and crib walling, that is exposed to the weather and is in contact with the ground.

**Note 1:** For structural use of other species, refer to NZS 3602:2003 Tables 1 and 2.

**Note 2:** For non-structural use of radiata pine, Douglas fir and other species, refer to NZS 3602:2003 Table 3.

**Note 3:** A higher treatment level also satisfies the level specified in this table.

## Untreated Douglas fir

The new timber treatment system for Acceptable Solution B2/AS1 allows untreated Douglas fir to be used in houses of a defined low-risk design. Research shows that Douglas fir resists decay better than untreated radiata pine, but not as well as H1.2 treated timber.

Untreated solid Douglas fir framing can be used for a house of no more than two storeys (as defined in NZS 3604), that is designed and constructed to NZS 3604, if ALL the following low-risk conditions are met:

### Low-risk house conditions

is a standalone, single household unit of no more than two storeys (as defined in NZS 3604), that is designed and constructed to NZS 3604

**AND**

is situated in wind zones no greater than 'high' as defined in NZS 3604

**AND**

has a building envelope complexity no greater than 'medium risk', and a deck design no greater than 'low risk', as defined by the risk matrix in the Acceptable Solution E2/AS1

**AND**

has drained and vented cavities complying with E2/AS1, behind all claddings

**AND**

uses roof and wall cladding systems and details meeting E2/AS1

**AND**

has a risk matrix score of no more than 6 on any external wall face, as defined in E2/AS1

**AND**

has a simple pitched roof with hips, valleys, gables, or mono pitches, all draining directly to external gutters\*

**AND**

has a roof slope of 10° or more

**AND**

if it has a skillion roof, the roofing material is corrugated iron or concrete, metal or clay tiles for adequate ventilation

**AND**

has eaves 450mm-wide or more for single-storey houses, and eaves 600mm-wide or more for two-storey houses.

\* The roof does not have internal or secret gutters, concealed gutters behind fascias, or any roof element finishing within the boundaries formed by exterior walls (for example, the lower ends of apron flashings, chimneys, dormers, clerestories, box windows).

## When the new system starts

---

From 4 April 2011 to 30 June 2011, both the previous B2/AS1 (amendment 6) and the new B2/AS1 (amendment 7) can be used as an Acceptable Solution for consenting purposes.

From 1 July 2011 onwards, only the new B2/AS1 can be used as an Acceptable Solution.

Know the new system - and frame it right first time.

## Safety and health

---

Timber treatments generally consist of chemicals that need to be handled safely and appropriately. Important measures to take when using treated timber, especially hazard classes H3 and above, are:

- reduce contact by wearing gloves, goggles and a dust mask
- don't burn off-cuts or cook with them
- dispose of waste in an approved landfill
- wash your hands before using the toilet, smoking or eating
- wash work clothes separately

- ventilate work spaces as much as you can
- working with solvent-damp timber is not advised, solvent-damp timber should be allowed to properly dry off before use.

Note: Boron has been used commercially as a timber preservative in New Zealand since the 1950s, with no known health issues for timber users or building inhabitants.

# Reference diagrams

## Roof framing: general New B2/AS1

- H1.2 Radiata pine
- H1.2 Douglas fir

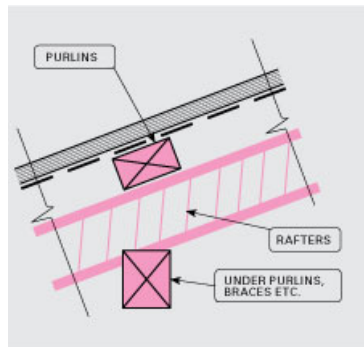

## Roof framing: solar driven moisture

### New B2/AS1

- H1.2 Radiata pine
- H1.2 Douglas fir

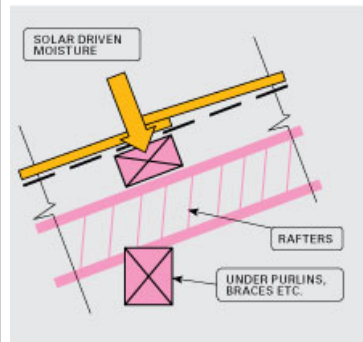

## Roof framing: solar driven moisture

### New B2/AS1

- H1.2 Radiata pine
- H1.2 Douglas fir

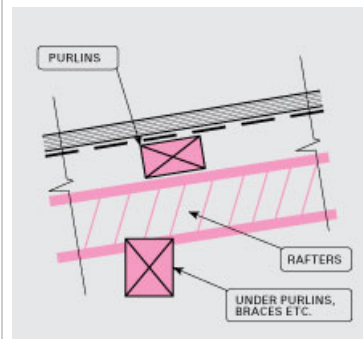



**Roof framing: Skillion roofs**

**New B2/AS1**

- H1.2 Radiata pine
- H1.2 Douglas fir

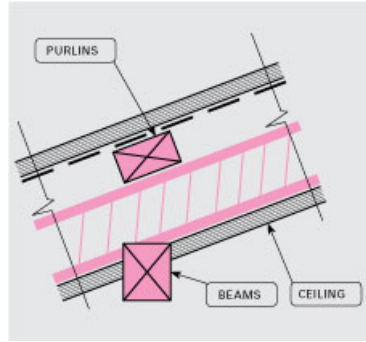

**Roof trusses:**

**New B2/AS1**

- H1.2 Radiata pine
- H1.2 Douglas fir

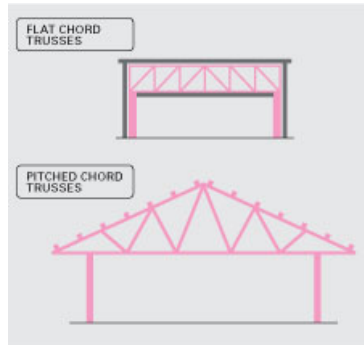

**Valleys, box gutters, purlins, battens, etc:**

**New B2/AS1**

- H1.2 Radiata pine
- H1.2 Douglas fir

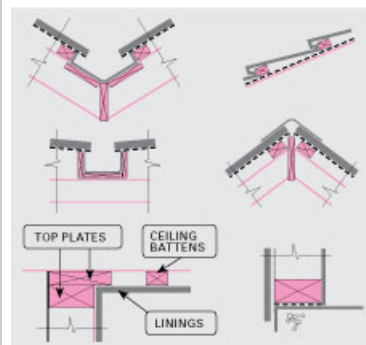

**Enclosed decks:****New B2/AS1**

- H1.2 Radiata pine
- H1.2 Douglas fir

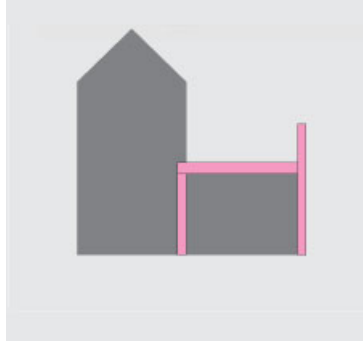
**Cantilevered enclosed decks:****New B2/AS1****Balustrade:**

- H1.2 Radiata pine
- H1.2 Douglas fir

**Cantilevered deck framing:**

- H3.2 Radiata pine

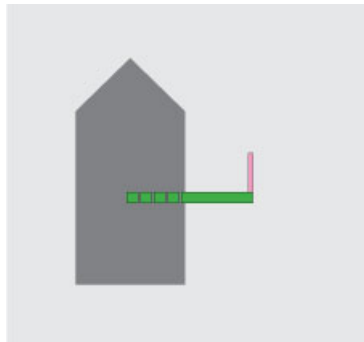
**Wall framing single-storey:****New B2/AS1**

- H1.2 Radiata pine
- H1.2 Douglas fir

**Or house of low-risk design:**

- Untreated Douglas fir

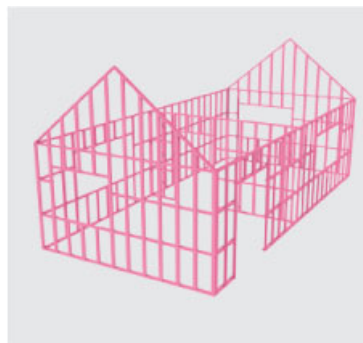

**Wall framing two-storey:**

**New B2/AS1**

- H1.2 Radiata pine
- H1.2 Douglas fir

**Or house of low-risk design:**

- Untreated Douglas fir

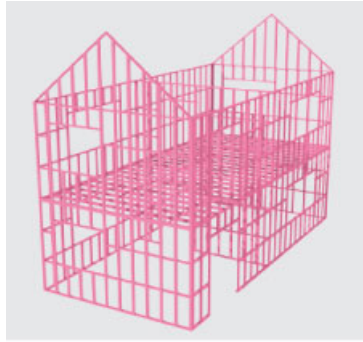

**Eaves, trimmers, parapets, furring, enclosed columns, etc:**

**New B2/AS1**

- H1.2 Radiata pine
- H1.2 Douglas fir

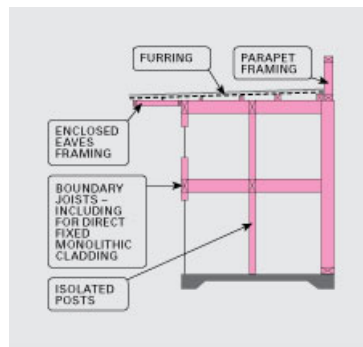

**Enclosed exterior elements:**

**New B2/AS1**

- H1.2 Radiata pine
- H1.2 Douglas fir

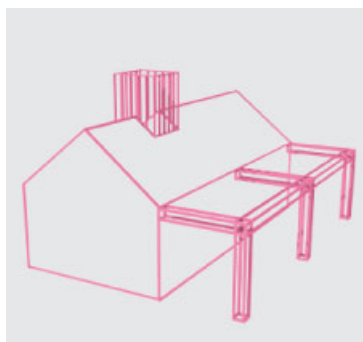

**Enclosed sub-floor framing:**

**New B2/AS1**

- H1.2 Radiata pine
- H1.2 Douglas fir

**\*DPC**

- Concrete piles – all cases
- Timber piles – between 150mm and 300mm above ground

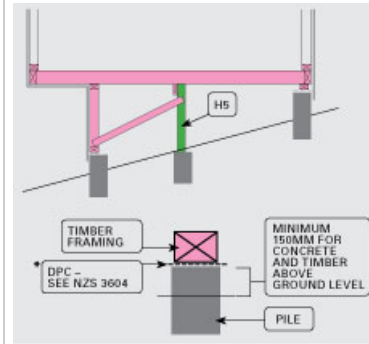

This information is published by the Ministry of Business, Innovation and Employment's Chief Executive. It is a general guide only and, if used, does not relieve any person of the obligation to consider any matter to which the information relates according to the circumstances of the particular case. Expert advice may be required in specific circumstances. Where this information relates to assisting people:

- with compliance with the Building Act, it is published under section 175 of the Building Act
- with a Weathertight Services claim, it is published under section 12 of the Weathertight Homes Resolution Services Act 2006.