



Dear Customer

Please find attached the January 2017 amendments to C/AS4 Acceptable Solution for Buildings with Public Access and Educational Facilities (Risk Group CA), published by the Ministry of Business, Innovation and Employment.

To update your printed copy of C/AS4, please make the following changes:

Section	Previous version	January 2017 Amendment 4
C/AS4 Acceptable Solution for Buildings with Public Access and Educational Facilities (Risk Group CA)		
Title pages	Remove document history/status	Replace with new document history/status
References	Remove page 7/8	Replace with new pages 7-8B
C/AS4 Part 1	Remove page 21/22	Replace with new page 21/22
C/AS4 Part 2	Remove page 29/30	Replace with new page 29/30
C/AS4 Part 4	Remove page 85/86	Replace with new page 85/86
C/AS4 Part 5	Remove pages 95/96, 105/106	Replace with new pages 95/96, 105/106
Appendices	Remove pages 117–120	Replace with new pages 117–120



MINISTRY OF BUSINESS,
INNOVATION & EMPLOYMENT
HĪKINA WHAKATUTUKI

C/AS4

Acceptable Solution for Buildings with Public Access and Educational Facilities (Risk Group CA)

For New Zealand Building Code Clauses
C1-C6 Protection from Fire

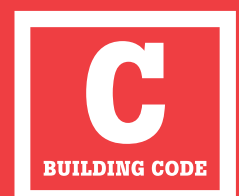

Using this Acceptable Solution

The Ministry of Business, Innovation and Employment may amend parts of this Acceptable Solution at any time. People using this Acceptable Solution should check on a regular basis whether new versions have been published. The current version can be downloaded from www.dbh.govt.nz/compliance-documents

Users should make themselves familiar with the preface to the New Zealand Building Code Handbook, which describes the status of Acceptable Solutions and explains other ways of achieving compliance.

Defined words (italicised in the text) are explained in the Building Code Clause A2 and in the Definitions section of this Acceptable Solution. Classified uses of buildings are explained in the Building Code Clause A1.

Enquiries about the content of this document should be directed to:



**MINISTRY OF BUSINESS,
INNOVATION & EMPLOYMENT**
HĪKINA WHAKATUTUKI

The Ministry of Business, Innovation and Employment
PO Box 10-729, Wellington 6140
Telephone 0800 242 243
Email: info@building.govt.nz

ISBN: 978-0-478-38174-0 (print)
ISBN: 978-0-478-38175-7 (electronic)

**Acceptable Solutions and Verification Methods are available
from www.building.govt.nz**

New Zealand Government

© Ministry of Business, Innovation and Employment 2016

This document is protected by Crown copyright, unless indicated otherwise. The Ministry of Business, Innovation and Employment administers the copyright in this document. You may use and reproduce this document for your personal use or for the purposes of your business provided you reproduce the document accurately and not in an inappropriate or misleading context. You may not distribute this document to others or reproduce it for sale or profit.

The Ministry of Business, Innovation and Employment owns or has licences to use all images and trademarks in this document. You must not use or reproduce images and trademarks featured in this document for any purpose (except as part of an accurate reproduction of this document) unless you first obtain the written permission of the Ministry of Business, Innovation and Employment.

Status of C/AS4

This Acceptable Solution C/AS4, for buildings with public access and educational facilities (Risk Group CA), provides a means of compliance with the New Zealand Building Code Clauses C1-C6 Protection from Fire. It is issued under section 22 of the Building Act 2004 as an Acceptable Solution.

This Acceptable Solution is one way that can be used to show compliance with the New Zealand Building Code Clauses C1-C6 Protection from Fire. Other ways of complying with the Building Code are described, in general terms, in the preface of the New Zealand Building Code Handbook.

When can you use C/AS4

This Acceptable Solution is effective from 1 January 2017. It can be used to show compliance with the Building Code Clauses C1-C6 Protection from Fire. It does not apply to building consent applications submitted before 1 January 2017.

The previous version, Amendment 2, of this Acceptable Solution can be used to show compliance with the Building Code Clauses C1-C6 Protection from Fire until 30 May 2017. It can be used for building consent applications submitted before 31 May 2017.

Document History			
	Date	Alterations	
New document	Effective from 10 April 2012	C/AS4 is a new publication that can be used to show compliance with the Building Code Clauses C1-C6 Protection from Fire.	
Amendment 1 (Errata 1)	Effective from 15 February 2013 until 18 June 2014	pp. 7–8 References pp. 13–14 Definitions p. 22 1.3 p. 25 Table 1.2 pp. 26–27 2.2.1, 2.2.3 p. 39 Figure 3.7 p. 44 Figure 3.12	p. 58 3.15.5 p. 89 4.17.7 pp. 91–106 5.2.1, 5.3.2, 5.5.4, 5.7.6 and 5.8.1, Figures 5.3 and 5.7, Table 5.2 p. 118 C4.1.2 and C5.1.1
Amendment 2	Effective from 19 December 2013 until 28 February 2015	pp. 7–8 References pp. 10 and 15 Definitions p. 20 Table 1.1 p. 22 1.3 p. 25 Table 1.2 pp. 26–30 2.2.1, 2.2.2, 2.2.8, 2.3.1, 2.3.13 p.34 3.3.2 p. 52 3.10.4 p. 58 3.15.2	p. 61 3.15.9 p. 67 4.4.4, 4.4.5 p. 75 4.13.5, 4.13.6 p. 80 4.15.6, 4.16.1 pp. 86–89 4.16.11, 4.16.12, 4.17.1, Table 4.1, 4.17.6 p. 110 7.2 p. 117 B2.1.1 p. 118 C6.1.2
Amendment 3	Effective from 1 July 2014 until 30 May 2017	p. 5 Contents p. 7 References p. 10, 14 and 15 Definitions pp. 20–22 1.1.3, 1.3, Table 1.1 p. 25 Table 1.2 pp. 26–27 2.2.1, 2.2.2, Table 2.0 p. 30 2.3.13 p. 35 3.3.2 p. 38 Table 3.2 p. 47 3.7.13 pp. 51–53, 55 3.10.2, 3.10.4, 3.10.5, 3.11.4, 3.11.1, 3.11.5, Figure 3.17A, Table 3.4	p. 58 3.15.2 p. 75 4.13.6 p. 80 4.15.6, 4.16.1 pp. 86–89 4.16.12, 4.17.2, 4.17.5, 4.18.1, Table 4.1 p. 91 5.3.1 p. 99 5.6.8 p. 101 5.7.6 p. 118 C2.1, C4.1.2, C5.1.1 p. 122 Index

Document History (continued)

	Date	Alterations	
Amendment 4	Effective 1 January 2017	pp. 8, 8A References p. 21 1.1.2 p. 29 2.3.1 p. 86 4.16.12	p. 96 5.5.7 p. 106 5.8.3 p. 118 C4.1.2, Table C1

References

For the purposes of New Zealand Building Code compliance, the New Zealand and other Standards, and other documents referred to in this Acceptable Solution (primary reference documents) shall be the editions, along with their specific amendments, listed below. Where the primary reference documents refer to other Standards or other documents (secondary reference documents), which in turn may also refer to other Standards or other documents, and so on (lower order reference documents), then the applicable version of these secondary and lower order reference documents shall be the version in effect at the date this Acceptable Solution was published.

Standards New Zealand		Where quoted
NZS/BS 476:- Part 21: 1987	Fire tests on building materials and structures	C5.1.1
	Methods for determination of the fire resistance of loadbearing elements of construction	
Part 22: 1987	Methods for determination of the fire resistance of non-loadbearing elements of construction	C5.1.1
AS/NZS 1668:- Part 1: 1998	The use of ventilation and air conditioning in buildings	3.10.4, 3.10.5, 4.16.12 Table 2.1, A2.1.1
	Fire and smoke control in multi-compartment buildings <i>Amend: 1</i>	
AS/NZS 2918: 2001	Domestic solid fuel burning appliances – installation	7.1.1, 7.1.2, 7.5.5, 7.3.3, 7.5.10 Comment, 7.5.12, Figure 7.2
NZS 4232:- Part 2: 1988	Performance criteria for fire resisting closures	Definitions
	Fire resisting glazing systems	
NZS 4332: 1997	Non-domestic passenger and goods lifts	6.4.3
NZS 4510: 2008	Fire hydrant systems for buildings	Table 2.1, A2.1.1
	<i>Amend: 1</i>	
NZS 4512: 2010	Fire detection and alarm systems in buildings	2.2.2, Table 2.1, 4.15.6, 6.2.1, A2.1.1, C6.1.6
NZS 4515: 2009	Fire sprinkler systems for life safety in sleeping occupancies (up to 2000 m ²)	Definitions, 2.3.13, 6.2.1, B3.1.1
NZS 4520: 2010	Fire resistant doorsets	4.2.4, 4.16.6, C6.1.1
NZS 4541: 2013	Automatic fire sprinkler systems	Definitions, 2.2.2, 2.3.13, 4.6.3, 5.2.2, 6.2.1, B2.1.1, Table 2.1
AS/NZS 5601:- Part 1: 2010	Gas installation	7.2.1, 7.2.2
	General installations <i>Amend: 1</i>	
Standards Australia		
AS 1366:- Part 1: 1992	Rigid cellular plastics sheets for thermal insulation	4.17.2
	Rigid cellular polyurethane (RC/PUR) <i>Amend: 1</i>	
Part 2: 1992	Rigid cellular polyisocyanurate (RC/PIR)	4.17.2
Part 3: 1992	Rigid cellular polystyrene – moulded (RC/PS-M)	4.17.2
	<i>Amend: 1</i>	
Part 4: 1989	Rigid cellular polystyrene – extruded (RC/PS-E)	4.17.2

Errata 1
Feb 2013

Amend 2
Dec 2013

Amends
2 and 3

Amend 2
Dec 2013

Amends
2 and 3

		Where quoted
	AS 1530:- Methods for fire tests on building materials, components and structures	
	Part 1: 1994 Combustibility test for materials	Definitions, C4.1.1
	Part 2: 1993 Test for flammability of materials	4.17.8, 4.17.9, C3.1
	Part 4: 2005 Fire-resistance tests of elements of building construction	4.5.9, C5.1.1
	AS 1691: 1985 Domestic oil-fired appliances – installation	7.3.1, 7.3.2
	AS 4072:- Components for the protection of openings in fire-resistant separating elements	
	Part 1: 2005 Service penetrations and control joints <i>Amend: 1</i>	C5.1.2
Errata 1 Feb 2013		
Amend 4 Jan 2017	AS ISO 9705: 2003 Fire tests – Full scale room test for surface products	Table C1
International Standards Organisation		
	ISO 5660:- Reaction-to-fire tests – Heat release, smoke production and mass loss rate	
	Part 1: 2002 Heat release rate (cone calorimeter method)	C4.1.2, C7.1.1, C7.1.2
	Part 2: 2002 Smoke production rate (dynamic measurement)	Table C1
Errata 1 Feb 2013		C4.1.2, Table C1 Amend 4 Jan 2017
	ISO 9239:- Reaction to fire tests for flooring	
	Part 1: 2010 Determination of the burning behaviour using a radiant heat source	4.17.3, Table 4.2, C2.1
Errata 1 Feb 2013	ISO 9705: 1993 Fire tests – Full scale room test for surface products	C4.1.2, Table C1 Amend 4 Jan 2017
European Standards		
	BS EN 12101 Smoke and heat control systems	
	Part 1: 2005 Specification for smoke barriers	Definitions
Errata 1 Feb 2013		
	EN 13501 Fire classification of construction products and building elements.	
	Part 1: 2007 Classification using test data from reaction to fire tests <i>Amend: 1</i>	Table C1
Amend 4 Jan 2017		
Building Research Establishment (UK)		
	BRE Defect Action Sheet DAS 131: May 1989	5.7.18 Comment
	External walls: Combustible external plastics insulation: Horizontal fire barriers	
	BRE Report 135: 1988	
	Fire performance of external thermal insulation for walls in multi-storey buildings. Rogowski B.F., Ramaprasad R., Southern J.R.	5.7.18 Comment
National Fire Protection Association of America		
	NFPA 285: 1998 Standard method of test for the evaluation of flammability characteristics of exterior non-load-bearing wall assemblies containing components using the intermediate scale, multi-storey test apparatus	5.8.2

American Society for Testing and Materials

ASTM D 2898: 2010 Standard practice for accelerated weathering of fire-retardant-treated wood for fire testing

New Zealand Legislation

Education (Early Childhood Services) Regulations 2008

Fire Safety and Evacuation of Buildings Regulations 2006

Hazardous Substances and New Organisms Act 1996

Australian Building Codes Board

National Construction Code

Where quoted

C7.1.3

Table 1.2

2.2.2, Definitions

1.1.5

Amend 2
Dec 2013

Table C1

Amend 4
Jan 2017

Outside the scope of this Acceptable Solution

1.1.2 *Buildings* or parts of *buildings* in *risk groups* other than CA are outside the scope of this Acceptable Solution. Refer to Table 1.1 and use the corresponding Acceptable Solution instead.

Buildings with complex features are outside the scope of this Acceptable Solution and also of the Acceptable Solutions C/AS1 to C/AS7 corresponding to other *risk groups*. Verification Method C/VM2 or an alternative solution shall be used instead. Complex features include:

- a) Atriums
- b) *Intermediate floors*, other than limited area *intermediate floors*
- c) Stadiums where tiered seating is provided for more than 2000 people or where the primary access for more than 100 people is above the level of the playing surface, and
- d) *Buildings* more than 20 storeys high.

If the Acceptable Solution cannot be followed in full, use Verification Method C/VM2 or an *alternative solution* to demonstrate compliance.

1.1.3 Other than where specifically required for early childhood centres, this Acceptable Solution allows for an ‘all out’ evacuation strategy only and does not provide features that would allow for delayed evacuation strategies.

1.1.4 THIS PARAGRAPH DELIBERATELY LEFT BLANK

Hazardous substances not covered by this Acceptable Solution

1.1.5 This Acceptable Solution does not provide for any use, storage or processing of *hazardous substances*. Compliance with NZBC F3 and the Hazardous Substances and New Organisms Act 1996 shall be ensured where applicable in addition to the requirements of this Acceptable Solution.

1.2 Using this Acceptable Solution

1.2.1 The process for using this Acceptable Solution shall be as follows.

Step 1: Determine which Acceptable Solutions apply

- a) Determine the *risk group* for each of the activities carried out in the *building* (refer to Table 1.1 and to Paragraph 1.1.1 of this and the other Acceptable Solutions). If the activity is not listed explicitly, choose the nearest suitable *risk group*.
- b) If there is more than one *risk group* for a *firecell*, determine its primary *risk group* (see Paragraph 1.2.2: this is the one with the most onerous *fire safety* requirements).
- c) Apply this Acceptable Solution for any *firecell* in *risk group* CA by following steps 2 and 3.
- d) Then apply the relevant Acceptable Solutions for *firecells* with any other *risk groups* in the *building*.

Comment:

Firecells: The Acceptable Solutions use the concept of *firecells* to divide *buildings* into compartments. Each *firecell* can be considered individually in the first instance and subsequently the *fire safety* requirements for the whole *building* can be developed, for example when considering a multi-storey *building* that has different activities on a number of floors, or even has different activities/uses on the same floor.

Future flexibility: A *building* is very likely to undergo one or more changes of use over its lifetime. Even under the same use, floor layout and furnishing will alter to accommodate changes in technology and occupant practices. Therefore, at the time of initial *construction*, *owners* should consider the advantages of providing for *fire safety systems* to suit alternative occupancies as these systems could be difficult or excessively expensive to install at a later date.

For Paragraph 1.2.1 Step 1 b), the most onerous *fire safety* requirements usually occur in Part 2: Firecells, *fire safety systems* and *fire resistance ratings* of each Acceptable Solution. *Buildings* or parts of *buildings* with sleeping occupancies generally have the most onerous requirements.

Amend 4
Jan 2017

Amend 4
Jan 2017

Amend 3
Jul 2014



Step 2: Determine the parameters for risk group CA

- a) Establish the relevant *building* measurements (these will include *building height*, floor plans, wall openings and distances to *relevant boundaries*).
- b) Work out the *occupant loads* for the relevant *building spaces* (refer to Paragraph 1.4).

Comment:
Applying the Acceptable Solution depends largely on the basic *building* measurements as above. Therefore, this should be determined as accurately as possible before using this document.

Step 3: Satisfy the fire safety requirements

Satisfy the *fire* safety requirements of this Acceptable Solution (refer to Parts 2-7), based on the *occupant loads* and on the *building's* dimensions and features where required.

Primary risk groups

1.2.2 If a *building* contains a number of different activities which individually may be categorised in different *risk groups*, the *risk group* designated for a particular *firecell* within a *building* shall be that of the primary *risk group*. The primary *risk group* shall be that one within the *firecell* that has the most onerous *fire* safety requirements.

1.2.3 Depending on the particular *building* and the uses or activities within that *building*, there may be several primary *risk groups*, with one or more on each floor.

Comment:
For example, levels of a multi-storey *building* may be categorised in different *risk groups* such as:

Basement carparks	VP
Shopping floors	CA
Office floors	WB
Domestic accommodation	SM

A single floor may also contain several *risk groups* such as:

Offices	WB
Shops	CA
Cafeteria	CA

1.3 Alterations and changes of use to buildings

If this Acceptable Solution is the basis of compliance of *building work* relating to an *alteration*, addition or change of use of an existing *building*, the *building work* shall comply fully with this Acceptable Solution.

Comment:
Sections 112 and 115 of the Building Act require the *means of escape from fire* of an existing *building* being altered, or the use being changed, to comply as nearly as is reasonably practicable with the Building Code.

Parts 1, 2, 3, and 4 of this Acceptable Solution may be used for an assessment of the *means of escape from fire* of an existing *building* that is being altered, to meet the requirements of section 112 of the *Building Act*.

Parts 1, 2, 3, and 4 of this Acceptable Solution may be used for an assessment of the *means of escape from fire*, and Part 5 for the assessment of *fire* rating performance, where an existing *building* is undergoing a change of use, to meet the requirements of section 115 of the Building Act.

The extent of assessment of the *means of escape from fire* of an existing *building* should follow the guidelines issued by MBIE "Requesting information about means of escape from fire for existing buildings". This considers a number of risk factors including:

- a) Age of the *building*
- b) *Importance level* of the *building*
- c) Extent of the *alteration*.

An existing *building* with a high *risk score* from the guidelines should be assessed against all of the *building* systems and features specified in Parts 1, 2, 3 and 4 of this Acceptable Solution, or alternatively be assessed using Verification Method C/VM2.

Sections 112 and 115 of the *Building Act* require the existing *building* to comply with other parts of the Building Code to at least the same extent as before the *alteration* or addition.

Errata 1
Amend 2

Amend 2
Dec 2013

Amend 2
Dec 2013

Amend 3
Jul 2014

2.2.5 Where *fire separations* are not needed between different *risk groups* on the same floor level, the *fire safety systems* adopted for the whole floor level shall be those of the primary *risk group* (as defined in Paragraph 1.2.2).

2.2.6 The *fire safety systems* required by Paragraph 2.2.3 shall be interconnected to alert all occupants of that floor level in the event of *fire*.

Comment:
Refer to Paragraphs 2.2.7 and 2.2.8 for the requirements for other floor levels in the *building*.

Other floors in a building

2.2.7 The alarm systems required in a *building* shall be interconnected to alert all *building* occupants in the event of *fire*, except:

- a) In areas that have the local smoke component of a Type 5 system.
- b) DELIBERATELY LEFT BLANK

Same risk group on different floors

2.2.8 Where *firecells* containing the same *risk group* occur at different levels in the same *building*, the *fire safety systems* for the *firecell* having the most onerous requirements shall be applied to all *firecells* in that *risk group*.

2.2.9 THIS PARAGRAPH DELIBERATELY LEFT BLANK

2.2.10 THIS PARAGRAPH DELIBERATELY LEFT BLANK

2.3 Fire resistance ratings

FRR values

2.3.1 Unless explicitly stated otherwise in this Acceptable Solution, the *fire resistance ratings (FRRs)* that apply for this *risk group* shall be as follows:

- Life rating* = 60 minutes
- Property rating* = 120 minutes.

Comment:
Throughout this Acceptable Solution, minimum *FRRs* are specified for particular situations. It is therefore essential to check for specific requirements.

Structural elements in a single storey *building* need not be *fire* rated if *FRRs* are not required for any other reason.

2.3.2 If a fire sprinkler system is provided, the *FRRs* for *risk group CA* shall be:

- Life rating* = 30 minutes, and
- Property rating* = 60 minutes.

2.3.3 If there is more than one *risk group* on one floor in the *building*, the highest required *FRR* shall be applied to common spaces and shared *escape routes* for that floor level.

General requirements for FRRs

2.3.4 *FRRs* shall apply to the sides of *primary* and *secondary elements* which are exposed to *fire*.

2.3.5 When different *FRRs* apply on each side of a *fire separation*, being a wall, the higher rating shall apply to both sides.

2.3.6 Floors shall have an *FRR* for exposure from the underside.

2.3.7 The *FRR* of a *primary element* integral with a *fire separation* shall be no less than that of the *fire separation*.

2.3.8 Except as required by Paragraph 4.3.3, areas of *external wall* not permitted to be *unprotected areas* shall be rated for *fire* exposure from within a *firecell*.

2.3.9 Areas of *external wall* not permitted to be *unprotected areas* shall be rated for *fire* exposure from both sides equally where:

- a) Walls are within 1.0 m of the *relevant boundary*, or
- b) The *building height* is more than 10 m.
- c) DELIBERATELY LEFT BLANK

2.3.10 THIS PARAGRAPH DELIBERATELY LEFT BLANK

2.3.11 Structural framing members connected to *building elements* with an *FRR* shall be rated at no less than the elements to which they are connected, or alternatively their connections and supports shall be designed so that their collapse during *fire* will not cause collapse of the *fire* rated elements.

Amend 2
Dec 2013

Amend 4
Jan 2017

Amend 2
Dec 2013



Applying insulation component in FRR

2.3.12 *Insulation* ratings shall apply to:

- a) All *fire separations*, except as noted in Paragraph 2.3.13
- b) Parts of *external walls* that are not permitted to be *unprotected areas*, and
- c) Parts of *external walls* which are within 2.0 m of an external *exitway* where it is a single *means of escape from fire* (see Paragraph 3.11.2).

2.3.13 *Insulation* ratings are not required to apply to:

- a) Glazing installed in accordance with Paragraph 4.2, or
- b) All elements where sprinklers are installed throughout the *building*, in accordance with either NZS 4541 or NZS 4515 as appropriate, or
- c) *Fire stops* in accordance with Paragraph 4.4.5, or
- d) *Fire dampers* and *damper blades* in accordance with Paragraph 4.16.12, or
- e) *Fire resisting glazing* in accordance with Paragraph 5.4.3.

Amend 3
Jul 2014

Amend 2
Dec 2013

Figure 4.16 Fire doors to separate floors above and below final exit level
Paragraph 4.16.9 d)

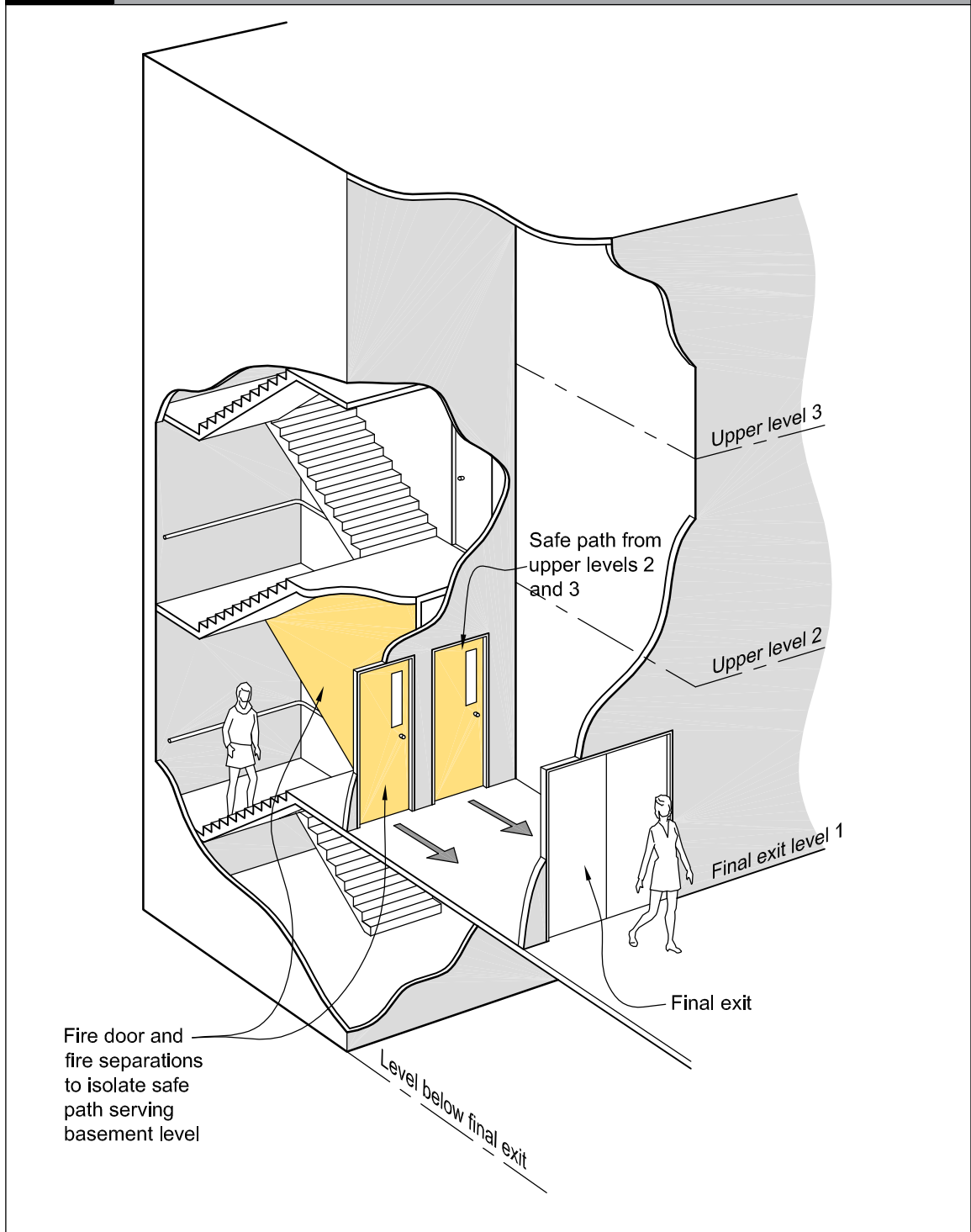

Protected shaft access panels

4.16.10 Access panels to *protected shafts* shall have the *fire* resistance performance as required by Paragraph 4.16.1 and shall:

- a) Be capable of being opened only with a special tool, and
- b) If smoke seals cannot be provided, be tight-fitting with a maximum total gap of 8mm around the panel (see Figure 4.17).

Lift landing doors

4.16.11 Other than where Paragraph 3.10.3 for a passenger lift within a vertical *safe path* applies, *doorsets* for lift landing doors opening into lift shafts which are *protected shafts* shall be *fire doors* complying with Paragraphs 4.16.1 to 4.16.3 except that an *insulation* rating is not required. Lift landing doors need not be *fire* rated from the shaft side.

Fire dampers

4.16.12 Any duct (unless fully enclosed by *construction* with an *FRR* no less than required for the *fire separation*) that passes through a *fire* or smoke separation shall not reduce the *fire* resistance and/or smoke separating function of the *construction* (excluding *external walls* and roofs) through which the duct passes.

Where a *fire damper* is used to maintain the required *fire* resistance it shall:

- a) comply with AS/NZS 1668.1, and
- b) have a *fire integrity* and *insulation* rating no less than that of the *fire separation*, except that the damper blade is not required to have an *insulation* rating if the *building* is sprinkler protected or means are provided to prevent *combustible* materials being placed closer than 300 mm to the *fire damper* and air duct.

Where a smoke damper is used to maintain the smoke separating function it shall:

- a) comply with AS/NZS 1668.1 and
- b) be actuated on alarm activation.

Fire dampers and smoke dampers shall be capable of being readily accessed for servicing.

Where evacuation is delayed and sprinklers are not provided, ventilation ducts that pass through a *fire* and/or *smoke separation* must provide a *smoke damper* complying with AS/NZS 1668.1.

Comment:

Delayed evacuation relates to any evacuation regime other than all *building* occupants moving directly to a *place of safety* outside, simultaneously and immediately on detection of *fire*.

Amend 3
Jul 2014

Amend 2
Dec 2013

Amend 2
Dec 2013

Amend 3
Jul 2014

Amend 2
Dec 2013

Amend 4
Jan 2017

Figure 4.17 Access panels
Paragraph 4.16.10

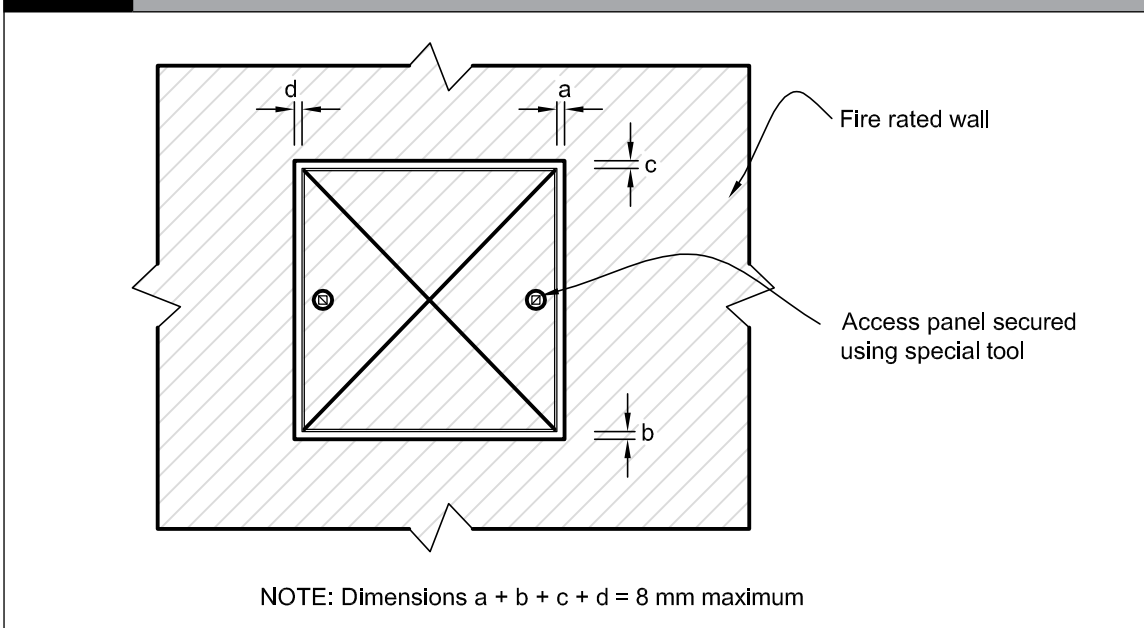
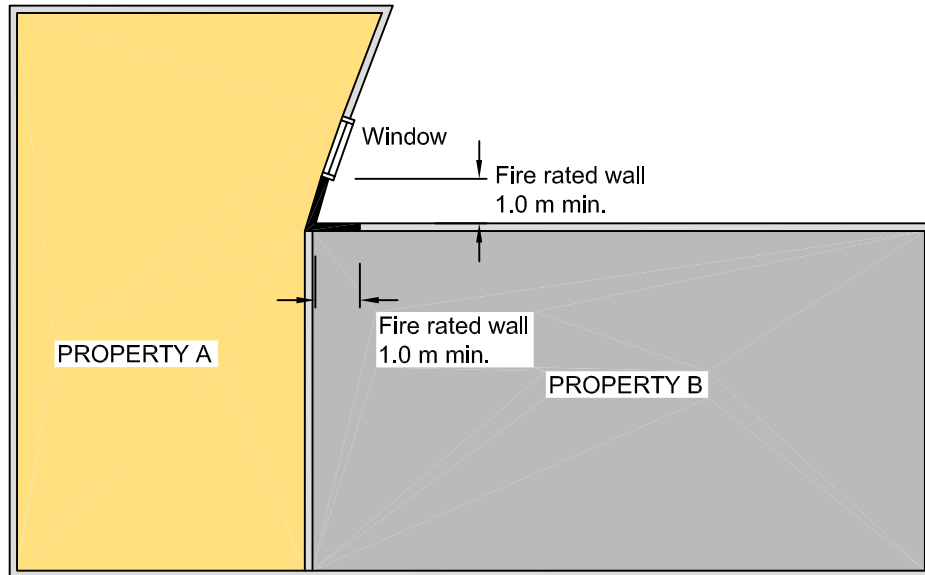
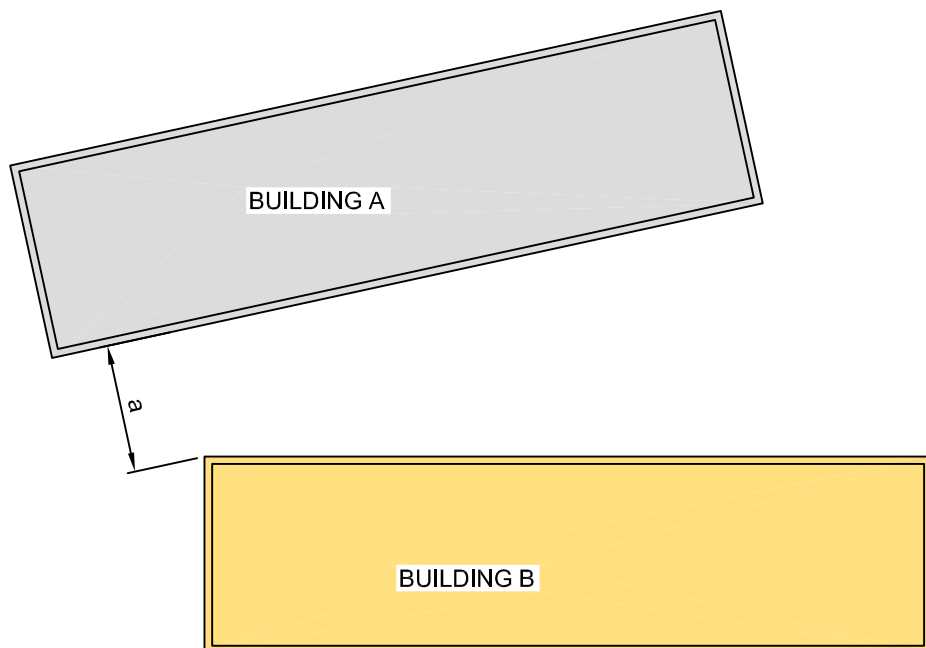

Figure 5.2 Separation of unprotected areas
Paragraph 5.5.1



(a) ADJOINING FIRECELLS



NOTE: a = distance to other building
(b) SEPARATE BUILDINGS

Figure 5.3 Measuring distance to relevant boundary
Tables 5.2 and 5.3 and Paragraph 5.5.1

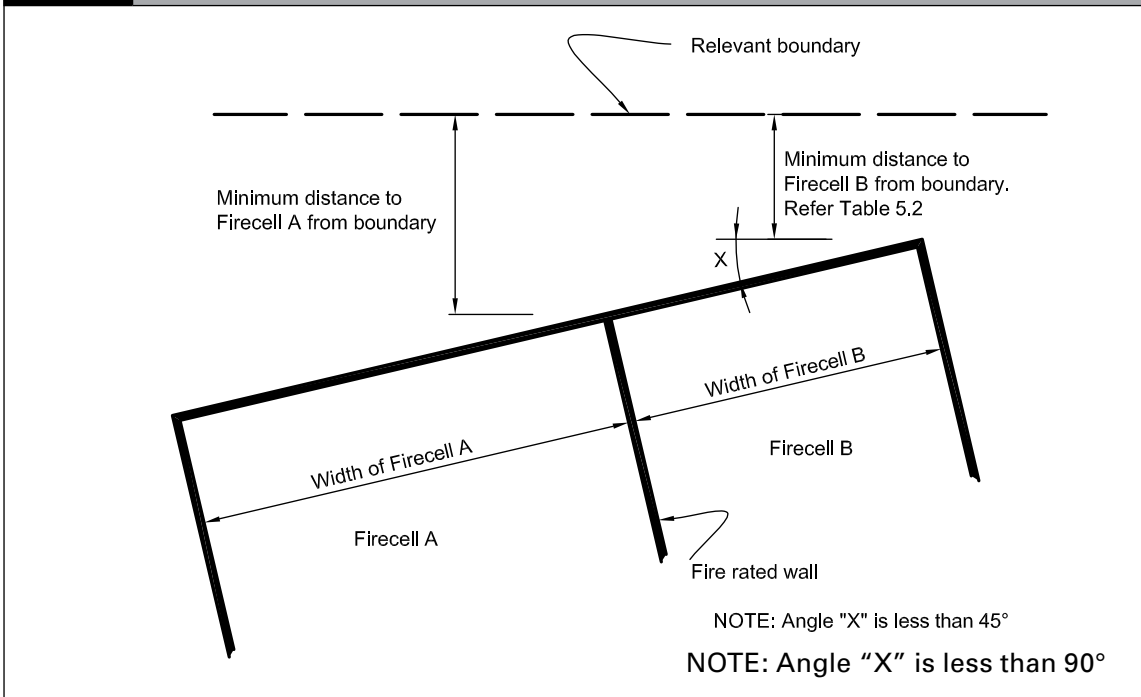

Errata 1
Feb 2013

5.5.2 The table method shall be used to determine the percentage of *unprotected area* in the *external wall* of each *firecell* depending on the distance to the *relevant boundary*.

5.5.3 Table 5.2 can also be used to determine the required distance from the *relevant boundary* where the percentage of *unprotected area* has previously been determined. Select the appropriate percentage (under the rectangle width column) and read the permitted distance to the *relevant boundary* from the left hand column of Table 5.2.

5.5.4 If Table 5.2 does not contain the exact measurements for the *firecell* being considered, use the next highest value for percentage area or next lowest value for *boundary distance*.

5.5.5 The largest individual *unprotected area* in the *external wall* and distance to any adjacent *unprotected areas* shall be restricted to the maximum dimensions specified in Table 5.3.

5.5.6 If the *firecell* is wider than 30 m, the *external wall* shall be divided into a number of 30 m widths and each of these can be assessed separately when considering the size of the largest individual *unprotected area*.

Comment:

This allowance permits the largest individual *unprotected area* to be repeated a number of times along the length of a *firecell external wall* without *fire rated construction* between each *unprotected area*.

5.5.7 As an alternative to the table method the Commentary to Verification Method Appendix A: Methodology for Horizontal Fire Spread (Tabular Data) can be used. For this method the tables for *unprotected area* and the wing/return wall tables in the Commentary must be used together.

Comment:

For guidance on the appropriate *FLED* refer to Table 2.2 of Verification Method C/VM2. This method requires a higher level of understanding of spread of fire to *other property* and should only be used by suitably qualified and experienced designers.

Amend 4
Jan 2017

Errata 1
Feb 2013

Figure 5.8 Barriers to vertical fire spread in foamed plastics external insulation systems
Paragraph 5.7.17

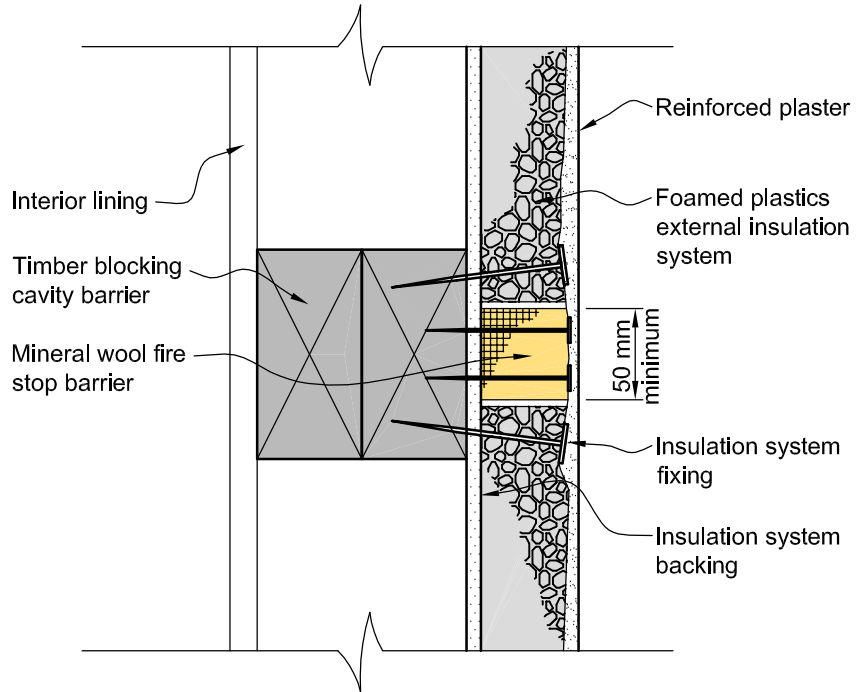

(a) Framed cavity wall construction

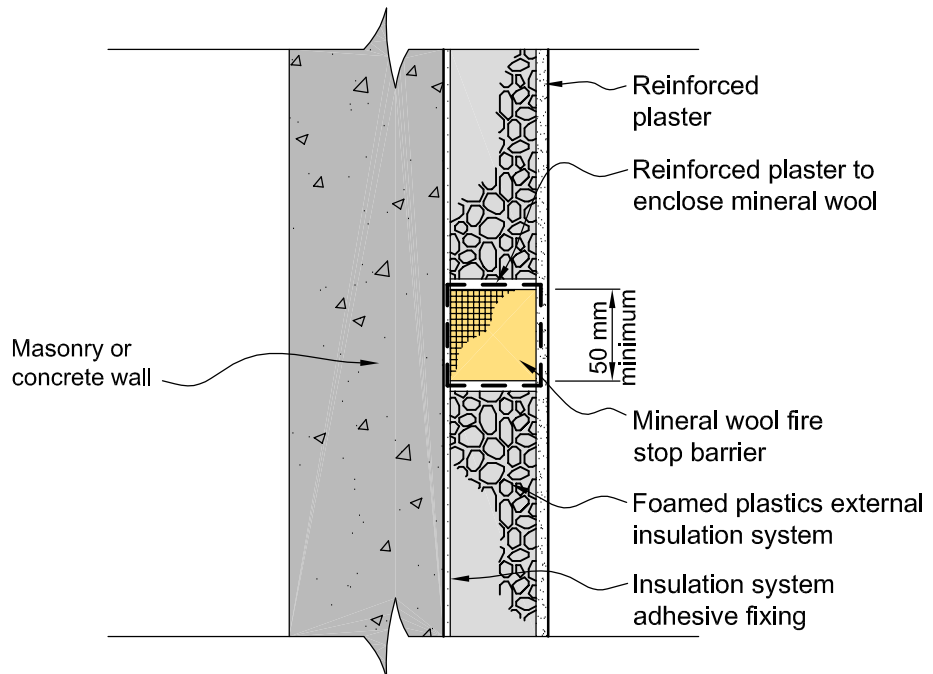

(b) Concrete or masonry wall construction

5.8 Exterior surface finishes

External walls

5.8.1 The *external wall* cladding system shall be tested in accordance with the relevant *standard test* in Appendix C C7.1 and shall satisfy the following requirements:

- a) If the distance to the *relevant boundary* is less than 1.0 m, the peak *heat release rate* shall not exceed 100 kW/m² and the total heat released shall not exceed 25 MJ/m², and
- b) If the distance to the *relevant boundary* is 1.0 m or more and the *building height* is greater than 7.0 m the peak *heat release rate* shall not exceed 150 kW/m² and the total heat released shall not exceed 50 MJ/m².

5.8.2 The requirements in Paragraph 5.8.1 do not apply if:

- a) *Surface finishes* are no more than 1 mm in thickness and are applied directly to a *non-combustible* substrate, or
- b) The entire wall assembly has been tested at full scale in accordance with NFPA 285 and has passed the test criteria.

5.8.3 THIS PARAGRAPH DELIBERATELY LEFT BLANK

5.8.4 If a *building* has *firecells* containing different *risk groups*, the acceptable peak *heat release rate* and total heat released of an *external wall* cladding system may have different values provided that:

- a) For each *risk group* the value is no greater than required by Paragraph 5.8.1 for the *building height* (not just the height of the *firecell*), and
- b) The value applied to a *firecell* is no greater than required by any *firecells* at a higher level on that wall.

Comment:

For *external walls*, the acceptable properties of *external wall* cladding systems depend on the *building height*, presence of sprinklers and the distance from the *relevant boundary*.

An *external wall* cladding system includes any applied *surface finish* such as paint or other coating combined with the substrate material. *Fire* tests should be carried out on samples representative of the finished product as used on the *building* to determine compliance.

While the specific *heat release rate* of a cladding system must be verified by *standard test* results, the following is an indication of the performance of some types of *construction*:

- *Non-combustible* materials such as concrete, brick, glass and steel meet the requirements of Paragraph 5.8.1
- Cellulose fibre-cement products with applied finishes/coatings less than 1 mm thick would usually meet the requirements of Paragraph 5.8.1, and
- Ordinary timber products would usually not meet the requirements of Paragraph 5.8.1.

Where the combustibility of a timber product is modified through the application of a *fire retardant* treatment to meet the requirements of Paragraph 5.8.1, it is to be subjected to pre-test accelerated weathering as described in Appendix C C7.1.3.

Errata 1
Feb 2013

Amend 4
Jan 2017

Appendix B (normative): Fire sprinkler systems

B1.1 Introduction

B1.1.1 Wherever sprinklers are required by this Acceptable Solution, they shall comply with the relevant New Zealand Standard, amended as shown in Paragraphs B2.1 and B3.1.

B2.1 Automatic fire sprinkler systems

B2.1.1 NZS 4541 is amended as follows:

Clause 103 Definitions

Sprinkler system A system including:

- (a) to (i) No change.
- (j) Delete.
- (k) Delete.
- (l) No change.

Clause 205 Delete entire clause.

Clause 209 Delete entire clause.

Clause 1203 Routine Surveys

Clause 1203.1 Delete first two paragraphs and replace with:

“It is important that a sprinkler system at all times complies with this Standard as amended by Paragraph B2.1 of Appendix B to C/AS4 in all respects. To ensure that building alterations, changes in process or storage patterns or progressive deterioration of system components do not prejudice system compliance, a comprehensive survey shall be carried out biennially at intervals not exceeding 28 months. Such surveys shall be carried out by an independent qualified person.”

B3.1 Residential fire sprinkler systems

B3.1.1 NZS 4515 is amended as follows:

Clause 1.5 Definitions

Sprinkler system A system including:

- (a) to (g) No change.
- (h) Delete.

Clause 1.11 Delete entire clause.

Clause 2.1.2 Delete.

Clause 2.1.3 Delete.

Amend 2
Dec 2013

Amend 2
Dec 2013

Appendix C (normative): Test methods

C1.1 General

This Appendix contains test methods for confirming that specific *building elements* satisfy relevant provisions of the Acceptable Solutions for Protection from Fire. It includes both established *standard tests* and other test methods for *building elements* in situations where *standard tests* are unavailable.

Comment:

Regardless of the year of the Standard incorporated by reference in this Acceptable Solution, there is no intention to require the *building elements* listed here to be retested to the current edition of the relevant Standard when they have previously been tested to an earlier version of that Standard in force at the date of testing.

Amend 3
Jul 2014

C2.1 Flammability of floor coverings

Materials shall be assigned a critical radiant flux when tested to:

ISO 9239 Reaction to fire tests for flooring – Part 1: Determination of the burning behaviour using a radiant heat source.

Or in lieu of testing refer to Table B1 of Appendix B in C/VM2.

Amend 3
Jul 2014

C3.1 Flammability of suspended flexible fabrics and membrane structures

Materials shall be assigned a *flammability index* when tested to:

AS 1530 Methods for fire tests on building materials and structures – Part 2: Test for flammability of materials.

C4.1 Properties of lining materials

C4.1.1 Combustibility test

Materials shall be classified as *non-combustible* or *combustible* when tested to:

AS 1530 Methods for fire tests on building materials and structures – Part 1: Combustibility test for materials.

C4.1.2 Materials for internal surface linings shall be given a *Group Number* in accordance with Appendix A of C/VM2 and tested to either:

ISO 5660 Reaction-to-fire tests
Part 1 Heat release rate (cone calorimeter method), and
Part 2 Smoke production rate (dynamic method), or

ISO 9705 Fire tests – Full scale room test for surface products

Or in lieu of testing refer to Table A1 of Appendix A in C/VM2.

Australian and European classifications can be used to achieve *Group Numbers* in Table C1.

Errata 1
Feb 2013

Amend 3
Jul 2014

Table C1 Alternative test or classification standards for Group Numbers		
Requirements according to C/VM2 Appendix A using ISO 9705 or ISO 5660	Requirements according to NCC Specification C1.10 Clause 4 using AS ISO 9705	European Classification using EN 13501-1
Group Number 1- S	Group Number 1, and a smoke growth rate index not more than 100	Class A1, A2 or Class B and Smoke production rating s1 or s2
Group Number 1	Group Number 1	Class A1, A2 or B
Group Number 2- S	Group Number 2, and a smoke growth rate index not more than 100	Class C and Smoke production rating s1 or s2
Group Number 2	Group Number 2	Class C
Group Number 3	Group Number 3	Class D
Group Number 4	Group Number 4	Class E and F

Amend 4
Jan 2017

C5.1 Fire resistance
.....

C5.1.1 *Primary and secondary elements, closures and fire stops* shall be assigned a *fire resistance rating (FRR)* when tested to:

- a) AS 1530 Methods for fire tests on building materials and structures – Part 4: Fire resistance tests of elements of building construction, or
- b) NZS/BS 476 Fire tests on building materials and structures – Parts 21 and 22.

C5.1.2 *Fire stops* shall be tested:

- a) In circumstances representative of their use in service, paying due regard to the size of expected gaps to be *fire stopped*, and the nature of the *fire separation* within which they are to be used, and
- b) In accordance with AS 4072: Components for the protection of openings in fire-resistant separating elements – Part 1: Service penetrations and control joints.

C6.1 Fire doors and smoke control doors
.....

C6.1.1 *Fire doors* shall be evaluated in circumstances representative of their use in service, and shall comply with NZS 4520 Fire-resistant doorsets.

Smoke control doors

C6.1.2 A door shall be deemed to be a *smoke control door* if, in addition to the requirements in this Acceptable Solution for *smoke control doors*:

- a) The door is a *fire door* that is fitted with appropriate smoke seals, or if:
- b) It is *constructed* with solid core leaves. Solid timber core leaves, when used, shall have a leaf thickness of no less than 35 mm, and
- c) It is provided with smoke seals as required by this Acceptable Solution. Smoke seals shall be in continuous contact with the mating element, and located so as to minimise interruption by hardware, and
- d) The frames are *constructed* of timber, and the jambs are no less than 30 mm thick, and

- e) Any vision panel cut-outs are no less than 150 mm from the leaf edges, and
- f) The maximum average clearances (excluding pre-easing) are:
 - i) Leaf to frame 3 mm
 - ii) Leaf to leaf 5 mm
 - iii) Leaf to top of any floor covering 10 mm, and
- g) Any additional facings shall be adhesive fixed, and
- h) It is provided with signage identifying it as a *smoke control door* in accordance with Acceptable Solution F8/AS1.

Frictional forces

C6.1.3 The forces required to open any *fire door* or *smoke control door* on an *escape route* shall not exceed 67 N to release the latch, 133 N to set the door in motion, and 67 N to open the door to the minimum required width. These forces shall be applied at the latch stile. These requirements do not apply to horizontal sliding doors in *risk group SI* or to power-operated doors.

Self-closing provision

C6.1.4 All *fire* and *smoke control door* leaves shall be self-closing, and provision shall be made for the self-closing device to be adjustable during commissioning to satisfy the requirements of Paragraph C6.1.3 after installation.

C6.1.5 Where it is desirable in normal circumstances for a *fire door* or *smoke control door* to operate freely, it is acceptable to use a self-closer mechanism which activates in the event of *fire* but does not operate at other times.

Comment:

1. These circumstances can occur where people are under care. Leaving the door to the occupant's room (or *suite*) open reduces that occupant's feeling of isolation and permits ready observation by staff.
2. Self-closers can be an obstruction to the elderly and *people with disabilities*, who may have difficulty in opening the door against the pressure applied by the self-closer. Acceptable Solution C/AS3 Paragraph 4.6 describes situations where smoke control doors do not have to be self-closing where they are used within a *group sleeping area* or *suite*.

Errata 1
Feb 2013

Amend 2
Dec 2013

Amend 2
Dec 2013



Automatic smoke-sensing devices

C6.1.6 Automatic smoke-sensing devices complying with NZS 4512, if used, shall be positioned within the stream of air that passes the door when the *smoke control door* is fully open.

C7.1 Fire properties of external wall cladding systems

.....

C7.1.1 Fire properties of *external wall cladding systems* shall be determined in accordance with:

ISO 5660 Reaction-to-fire tests –
Heat release, smoke production and mass loss rate –
Part 1: Heat release rate (cone calorimeter method).

C7.1.2 In addition to meeting the general requirements of ISO 5660 Part 1, testing shall be in accordance with the following specific requirements:

- a) An applied external heat flux of 50 kW/m², and
- b) A test duration of 15 minutes, and
- c) The total heat release measured from start of the test, and
- d) Sample orientation horizontal, and
- e) Ignition initiated by the external spark igniter.

C7.1.3 Timber claddings which have a *fire retardant* treatment incorporated in or applied to them shall be subjected to the regime of accelerated weathering described in ASTM D 2898 Method B with the water flow rate from Method A before testing in accordance with the requirements of Paragraph C7.1.1.

C7.1.4 *External wall cladding systems*, which comprise only materials which individually are classified as *non-combustible*, may be deemed to satisfy all the requirements of Paragraph 5.8.1.

Comment:

The *non-combustible* classification represents a more onerous performance level than those required by Paragraph 5.8.1 and is therefore acceptable. A *non-combustible* classification may be claimed only if the respective materials have been subjected to testing as described in Paragraph C7.1.1.

C7.1.5 Claddings incorporating a metal facing with a melting point of less than 750°C covering a *combustible* core or insulant shall be tested as described in Paragraph C7.1.2 without the metal facing present.

Comment:

Aluminium has a melting point of less than 750°C.